

Fountaine Pajot
C A T A M A R A N S



Sailing Multihulls 2011 / 2012



About Us

Multihull Solutions is Australia and New Zealand's leading offshore and cruising multihull specialist.

With a range of new multihulls from international names including Catana, Sunreef Yachts, Fountaine Pajot and Trawler Catamarans, we bring a new level of service and choice to this specialist market.

In addition to its range of premier new boats, Multihull Solutions has a quality Pre-Owned Brokerage with an extensive array of multihulls priced from AUD\$250,000 to \$10 million.

If you are considering investing in the charter industry, we also offer a comprehensive range of multihulls in some of the most exotic locations in the world. Explore our various charter yacht investment options that represent a sensible and balanced lifestyle investment with fixed and variable income options.

Powered by an absolute commitment to providing the very best service and advice, the Multihull Solutions team comprises some of the most experienced and best people in this area of the industry.

Multihull Solutions also provides a comprehensive Services Division that can assist with all aspects of multihull ownership and operation, including:

- Tuition and sail training;
- Insurance and ocean passage cover;
- Shipping and transport facilitation;
- Vessel management and maintenance;
- Refitting and custom design;
- Relocations, deliveries and much more.



Fountaine Pajot	4-5
Yacht models	6-7

Sail Cruising Range

Mahé 36 Evolution information	8-9
Mahé 36 Evolution specifications	10-11

Lipari 41 information	12-13
Lipari 41 specifications	14-15

Orana 44 information	16-17
Orana 44 specifications	18-19

Salina 48 Evolution information	20-21
Salina 48 Evolution specifications	22-23

Flagship Class

Sanya 57 information	24-25
Sanya 57 specifications	26-27

Galathea 65 information	28-29
Galathea 65 specifications	30-31

Day Charter Range

Taïiti 60 & 80 information	32-33
Putting your boat in charter	34-37

Summary	38
---------	----

Fountain Pajot



Founded by Jean-François Fontaine and Yves Pajot in France in 1976, Fountain Pajot is now the world's leading manufacturer of cruising catamarans having built more than 2200 sail and power multihulls. With two state-of-the-art production sites in La Rochelle - the heart of one of the world's most important boatbuilding regions - Fountain Pajot employs an elite multidisciplinary team of more than 400 people and is renowned for its continued investment in technology, production industrialisation, research and design.

Manufacturing

The construction of Fountain Pajot catamarans includes verifications at every stage in conformity with ISO 9001. The fibreglass fabrics are checked before use and each stage of lamination is followed by an inspection. Pressure during vacuum-gluing operations is continuously measured and the quality of the result is systematically checked over the whole glued surface. The hardness of the composite is measured on each element using the Barcol procedure, and samples taken from each boat are kiln-tested in order to verify resistance to hydrolysis. The resistance to wear and weathering of the adhesives used for the lining and floors are also tested.

There is complete traceability of every unit that leaves the yard – a rigorous system essential for subsequent maintenance. The company's technical department and engine manufacturers conduct sea trials on all boats to guarantee delivery in perfect condition.

Quality Inspections

When completed, the boat goes to the test basin where all of its equipment is tested, and a sprinkler system checks the whole structure is completely watertight. For future reference, the technical department maintains a comprehensive file on every vessel, which contains the details of all the materials and products used and all equipment installed. Exact drawings of certain specific components are also archived, as well as samples of the composite.

I.C.N.N Product Certification

All Fountain Pajot catamarans possess 'EC Type' I.C.N.N Product Certification in conformity with European directive 94/25 CE. The Fountain Pajot yard is also the first French boat builder to have obtained ISO 9001 Quality certification for the entire production cycle of its vessels. This certification is an international standard designed to improve customer satisfaction, ensuring the company continues to build on its high standards of product and management procedures.

Safety

Unsinkability

Unsinkability and the bulkhead structure inside Fountain Pajot's catamarans are key elements in their safety. Unsinkability is ensured by volumes of foam placed in the forward and rear extremities of the hulls.



The watertight bulkheads in the stem of each hull provide total isolation; even after an impact causing a leak, only the forward compartment floods and the boat can continue to sail.

Fins

Fixed fins

For safety reasons the fins are completely separate components to the hulls – a feature that preserves and protects the watertightness of the boat in the event of a violent impact, and also makes them easier to repair or replace if required.

Shock-resistant fins

The use of fin keels over daggerboards provides numerous advantages: they are fixed and therefore require no manipulation; they give perfect protection to drive shafts, propellers, rudder blades and hull bottoms in the event of grounding; the absence of a daggerboard case saves space; their wind-tunnel designed profiles give exceptional performance and generate no turbulence or vibration.

Technology

Fontaine Pajot catamarans are built from a sandwich structure with a PVC foam core laminated under vacuum. Fontaine Pajot leads the industry in this technology, consistently making significant investment in the advancement of injection moulding technology to allow resin

injection at far higher pressure, delivering a lighter, stronger and more consistent product. For ultimate protection against hydrolysis, only isophthalic gelcoats are applied to hulls and decks by spray-gun. Also, the recent introduction of vinylester rather than polyester resins from the waterline down further enhances strength and hydrolysis resistance.

Custom-made fabrics

Fontaine Pajot, in collaboration with Chomarat, has designed their own fabrics with mono and multidirectional fibres in different weights in order to optimise the weight and structure of the boat. In accordance with the quality control process, for every model an exact sample of each fabric allocated to specific zones in the vessel is prepared and recorded. The choice and composition of fabrics differs according to the zone orientation to ensure fabric weights are optimised with respect to the stresses distributed throughout the boat.

Infusion Process

The entire structure of the boat is built up in layers of dry-bonded fabric. Under vacuum, the resin is able to penetrate into every empty space in a single operation, which affords multiple advantages: protection of the environment and anticipation of new regulations relating to solvents; improved working conditions, and a perceptible weight saving resulting in improved sailing performance.

Sail Cruising Range

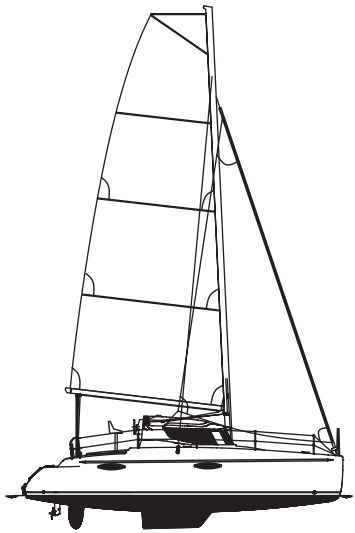

Mahé 36 Evolution

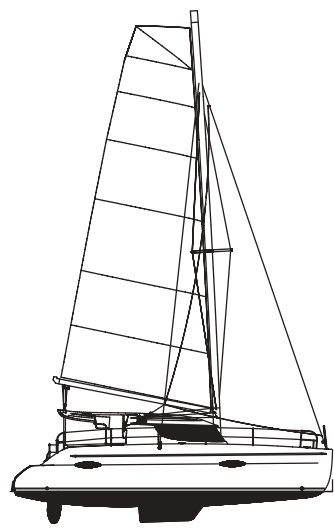

Lipari 41

Flagship Class

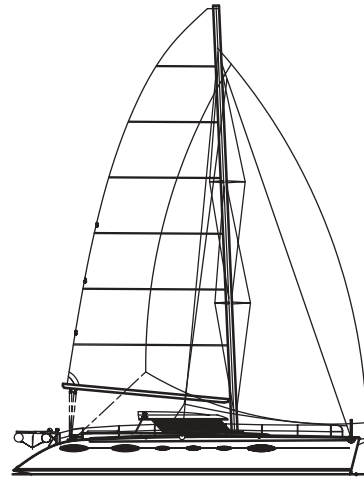

Sanya 57

Day Charter

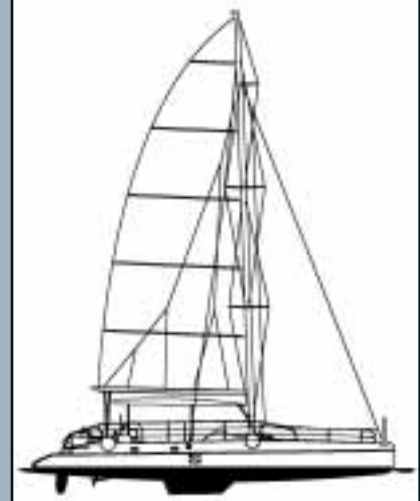

Taiti 60

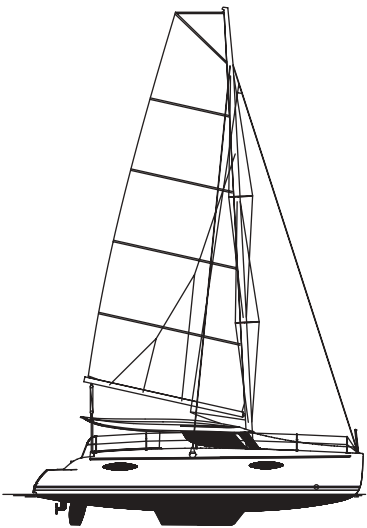

Orana 44



Salina 48 Evolution

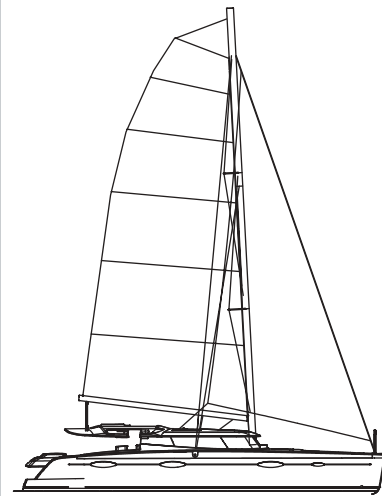

Galathea 65

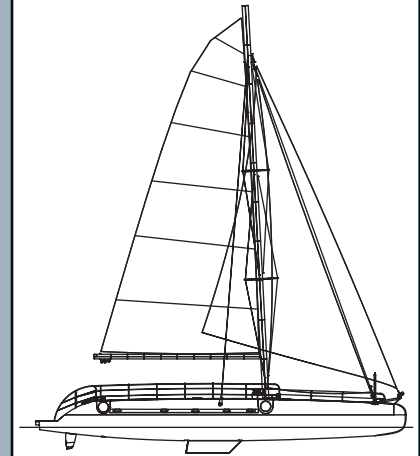

Taiti 80

Yacht Models

Sail Cruising Range

Fountaine Pajot started building cruising catamarans in 1983 with a vision to develop a complete range of entry level through to large ocean going, world cruising catamaran designs. At this early stage in the development of production catamarans, Fountaine Pajot set out with the focus on innovative, safe, unsinkable and seaworthy designs that are now the benchmark for the world catamaran market.

Today, after the development of more than 27 models and more than 2200 catamarans built, the company offers an exciting, up-to-date range of sailing catamarans comprising the Mahé 36 Evolution, Lipari 41, Orana 44, Salina 48 Evolution, Sanya 57, Galathea 65, and the well known day charter Taiti 60 and 80. Specifications, layouts and information on these models are detailed in the following pages.

To remain the leading cruising catamaran builder in the world market, Fountaine Pajot has added new levels of comfort and introduced the most advanced construction technology. The company is generating sustained profits for future development through its international activities.



Flagship Class

Flagship Class

The Fountaine Pajot Flagship Class presents the most exclusive cruising catamarans to the market, defined by majestic lines, superior quality of finish and a luxurious level of comfort. Designed by the internationally renowned firm Berret-Racoupeau Yacht Design, the Flagship Class exudes timeless style without compromising performance and safety standards.

Fountaine Pajot's Flagship Class of sailing catamarans includes the brand new Sanya 57 and Galathea 65, which offer discerning buyers an incomparable cruising experience. Weekend or long-distance cruising is a pleasure with their spacious and ambient saloons, generous and impeccably furnished cabins and expansive gourmet galleys designed for entertaining.

Day Charter

Fountaine Pajot also enjoys strong success in the international tourism market with many boats available around the world in charter fleets. Our Taiti 60 and Taiti 80 day charter catamarans offer customised layouts and options and are designed for resort and tourism operators to carry up to 100 guests to the most remote locations in absolute comfort and safety.

Mahé 36 Evolution

The exciting new Mahé 36 Evolution features a host of improvements and new features to its predecessor, including a rigid cockpit bimini, redesigned galley, additional refrigeration, improved ventilation and numerous interior upgrades.

The changes contribute to making the Mahé 36 Evolution the best value 11-metre catamaran on the market, making catamaran sailing accessible to new clients on a reasonable budget, while still offering the superior performance and construction qualities commonly found in larger and more prestigious catamarans.

The Mahé 36 Evolution was designed to meet three stringent objectives: to be affordable while offering excellent value for money, be ergonomic and comfortable, and lastly to possess outstanding sea performance with centralised handling.

Also featuring a sheltered open-plan cockpit, a clean and uncluttered deck layout, plus a raised helm station boasting 360-degree vision with centralised commands, the Mahé 36 Evolution's innovative exterior design complements its outstanding performance.

The spacious saloon measures 15m² (161.46ft²) and affords excellent headroom (1.90m), ample storage and unrivalled comfort.



The Mahé 36 Evolution is available in two versions to satisfy the most demanding requirements of individuals and charter operators.

The Mahé 36 Evolution's cabins are impressive: generous in size, beautifully lit, well-ventilated and very private with exceptional cabin roof space, creating a comfortable retreat for owners and guests.

Whether weekend cruising or challenging the elements during offshore passages, the Mahé 36 Evolution simply excels offering outstanding performance in choppy conditions without compromising safety or comfort.

The two-cabin version features two private suites with a door at the bottom of the companionways as well as two bathrooms. The three-cabin version features two double cabins and an exclusive Owner's Suite.

Already a favourite in the world's charter fleets, the Mahé 36 Evolution is also appreciated by multihull owners who recognise quality and performance at a surprisingly affordable price.





Mahé 36 Evolution

Specifications	
LOA	11.00 m / 36.08 ft
Beam	5.90 m / 19.35 ft
Draft	1.10 m / 3.60 ft
Air Draft	16.75 m / 54.95 ft
Displacement	5 tonne
Sail Area Genoa	30 m ² / 280 sq ft
Sail Area Mainsail	47 m ² / 527 sq ft
Engines – larger optional	2 x 20 hp
Freshwater Capacity – larger optional	2 x 265 litre
Diesel Capacity – larger optional	1 x 200 litre
Architects and Designer	Joubert - Nivelt / Olivier Flahault Design
Layout Options	Standard – 3 doubles / 1 bathroom Owner's – 2 doubles / 2 bathrooms

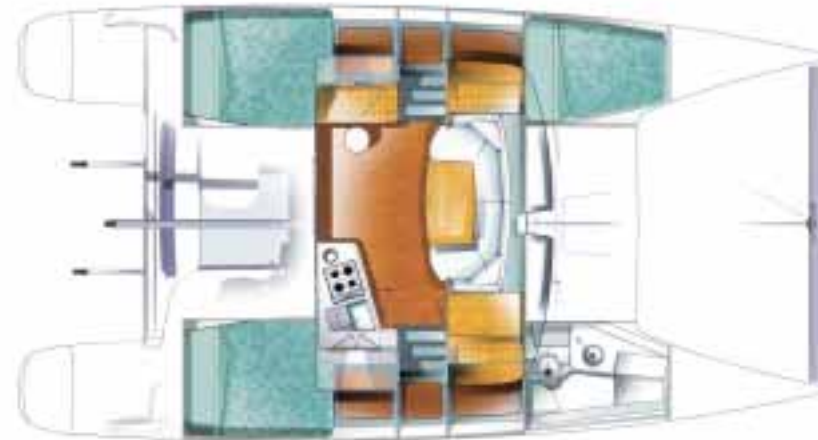

Standard Version

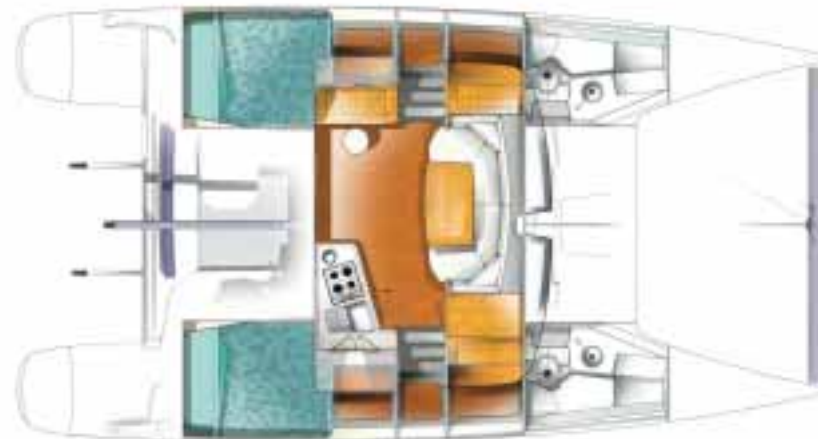

Owner's Version

Lipari 41

The stunning Lipari 41 is a world class cruising multihull that shatters the benchmarks set by its peers. Replacing the immensely popular Lavezzi 40, the Lipari 41 brings with it enhanced performance and design.

The catamaran has been constructed with a low centre of gravity and light displacement of 7.6T to ensure safety, stability with optimal comfort and performance in all conditions. Its two 20Hp standard engines provide a cruising speed of 7.7 knots, while the option of two larger 30Hp engines offers up to 9.5 knots if required.

Aesthetically, the Lipari 41 represents the pinnacle of European excellence with elegant lines and a revolutionary design that maximises space, storage and comfort.

The catamaran's ergonomically designed deck provides convenient centralised handling with obstacle-free movement. Built with advanced RTM éco technology, the Lipari 41 outshines its competitors in innovation with the mast built into the deck rather than the roof for reinforced structural rigidity and ease of handling.

The Lipari 41 also features an integrated dual-seating helm station with excellent visibility and has the cockpit and saloon on the same level to help make short and long passages a cruising pleasure.



The cockpit features all-weather protection, ample seating for eight guests, a stainless steel framed dining table and open-plan entertaining facilitated by a large sliding door opening into the saloon.

Inside, the saloon and galley have been designed for spacious and relaxed living with large windows that provide outstanding natural light, ventilation and visibility, beautiful timber cabinetry and the highest standard of fixtures, trims and upholstery. Dining for eight is comfortably accommodated with the saloon's stylish table that also has stainless steel legs, an integrated plate stand and extraordinary under-bench storage. The adjacent chart table is also large, comfortable and practical.

The generously-equipped galley has been cleverly designed to ensure entertaining onboard is a breeze with an easy access 'piano-hinged refrigerator', outstanding storage and quality designer fixtures.

Each of the roomy cabins is well-ventilated with large portholes, superb visibility and an abundance of hanging and cupboard space.

The Lipari 41 is available in two versions: The Standard features four cabins with two separate bathrooms and is ideal for family and charter use. The three cabin is a true Owner's version with an exclusive private suite in the starboard hull including a decadent queen sized bed, desk, library and beautiful ensuite with contemporary designer fixtures.





Lipari 41

Specifications	
LOA	11.95 m / 39.20 ft
Beam	6.73 m / 22.10 ft
Draft	1.15 m / 3.77 ft
Air Draft	17.56 m / 57.60 ft
Displacement	7.6 tonne
Sail Area Genoa	33.5 m ² / 360 sq ft
Sail Area Mainsail	56 m ² / 603 sq ft
Engines – larger optional	2 x 20 hp
Freshwater Capacity – larger optional	2 x 265 litre
Diesel Capacity – larger optional	1 x 250 litre
Architects and Designer	Joubert - Nivelt
Layout Options	Standard – 4 doubles / 2 bathrooms Owner's – 3 doubles / 2 bathrooms

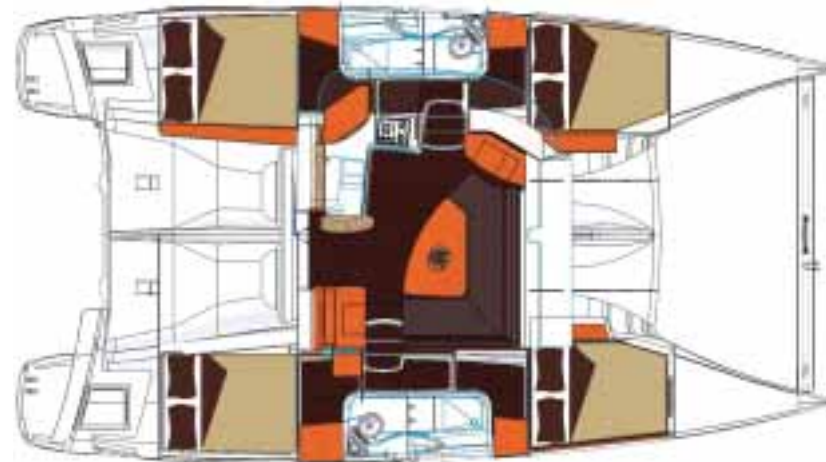

Standard Version

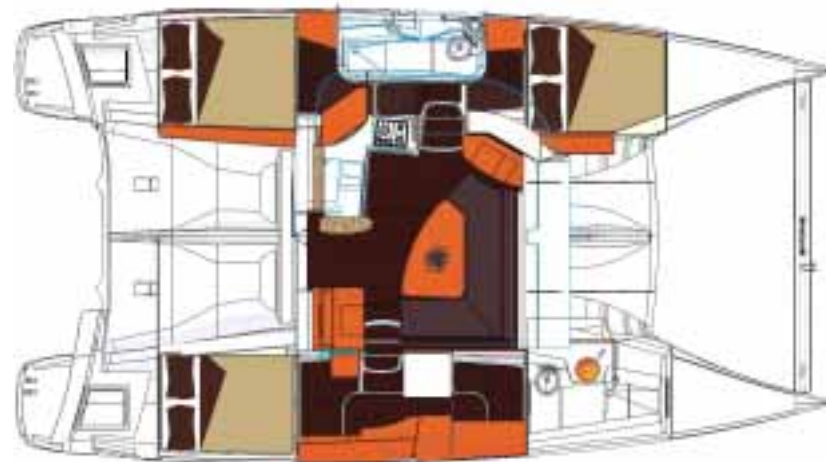

Owner's Version

Orana 44

The highly anticipated Orana 44 replaced one of Fountaine Pajot's greatest successes, the Belize 43.

Designed by renowned Joubert/Nivelt team, the Orana 44 is ideal for high-performance ocean sailing or modified for charter operators.

Boasting a high degree of comfort, the Orana 44 has a low centre of gravity to afford maximum safety and with a generous 110 square feet of sail area.

New manufacturing technologies employed in the vessel include a single piece hull infused with composite partitions and a deckhouse constructed with RTM eco-technology, ensuring it affords complete respect to the environment.

An innovative sliding bay provides direct open-plan access between the spacious saloon and cockpit, enhancing safety and ease of movement.

The ergonomic helm station accommodates three people and groups all navigational manoeuvres together affording excellent visibility above the deckhouse.

The Orana 44 has sleek lines and perfect proportions with a rigid bimini that is seamlessly integrated into the overall design. Inside there is excellent headroom and a spacious ambience that has been achieved without compromising exterior aesthetics.



A sunbathing deck aft of the catamaran features two mattresses with deck-chair style adjustments for optimal comfort.

The luminous interior comprises a light and airy galley that opens onto the cockpit, a beautiful saloon table that seats eight people with panoramic views, as well as a card table that faces the sea.

The galley is comprehensively equipped and features Fountaine Pajot's famous 'piano refrigerator' and ample space for cooking and preparation while overlooking the spacious saloon.

Each of the four cabins aboard the Orana 44 enjoys its own private bathroom with separate shower, while sliding doors in the companionways provide exceptional privacy for every guest. The Owner's suite in the Owner's version is fitted with an island bed, while the two supplementary cabins have semi-island style beds.

The Orana is powerful and commanding in inclement conditions, maintaining a high degree of comfort and stability courtesy of its advanced design and good forward volume. Easily managed single-handedly in all conditions, the catamaran is also a delight to sail in lighter breezes.





Orana 44

Specifications	
LOA	13.10 m / 43.1 ft
Beam	7.35 m / 24.11 ft
Draft	1.20 m / 3.94 ft
Air Draft	19.45 m / 63.80 ft
Displacement	9.8 tonne
Sail Area Genoa	45 m ² / 489 sq ft
Sail Area Mainsail	68 m ² / 732 sq ft
Engines – larger optional	2 x 30 hp
Freshwater Capacity – larger optional	2 x 265 litre
Diesel Capacity – larger optional	1 x 400 litre
Architects and Designer	Joubert - Nivelv
Layout Options	Standard – 4 doubles / 4 bathrooms Owner's – 3 doubles / 3 bathrooms

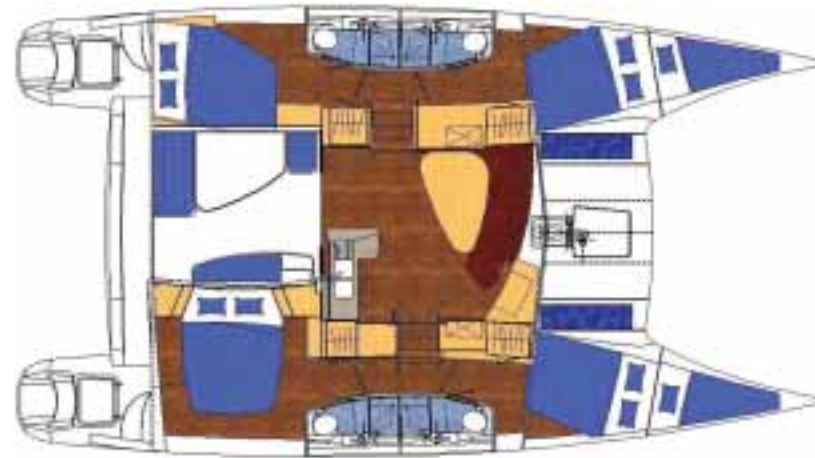

Standard Version



Owner's Version

Salina 48 Evolution

With upgrades inspired by Fountaine Pajot's exclusive Flagship range, the exciting new Salina 48 Evolution has been launched to critical acclaim.

The sleek sailing catamaran by Fountaine Pajot replaces the Salina 48, and was strategically planned to impress with a stunning new interior design, improved helm station, upgraded galley and roomier hulls. Like its predecessor, the Salina 48 Evolution is an extremely capable offshore catamaran, ideally suited to blue water cruising with an emphasis on stability, comfort, safety and spaciousness.

The Salina 48 Evolution has been designed to the most demanding list of specifications by architects Berret/Racoupeau. Its length (48'/14.30 m) gives it a slender shape with a very low centre of gravity for optimal comfort and safety at sea while its 136m² sail plan performs very effectively with minimal pitch in more choppy conditions.

Emulating a gourmet commercial kitchen, the Salina 48 Evolution's galley is a dream for offshore entertaining. With dark Corian benchtops, a four-burner stainless steel stove, brushed stainless steel sink, bar, customised timber cabinetry and excellent storage, the galley sets new standards in marine design. The Salina 48 Evolution also features an improved saloon with an elegant dining table that seats eight guests, which converts to a coffee table to optimise the spacious lounge area.



The catamaran has been redesigned to maximise space and storage in the passageways, while larger portholes afford even more natural light and unforgettable views.

A redesigned, raised steering station is fully protected from the sun and seats three people featuring direct, ergonomic access to the cockpit. Also, with the cockpit, saloon and steering station seamlessly integrated, the Salina 48 Evolution enables the helmsman and guests to enjoy easy, uninterrupted communication.

The Salina 48 Evolution has been manufactured with new technology including an infused sandwich composite hull plus a deckhouse moulded with new RTM eco-technology. A decadent sunbathing deck at the aft of the Salina 48 Evolution enjoys exceptional protection from the elements while underway and provides yet another idyllic setting for relaxation.

The Salina 48 Evolution is available in two versions; The Quatuor version comprises four cabins and four bathrooms while the Maestro version has a private owner's suite separate to the guest accommodation with a bathroom that will impress.





Salina 48 Evolution

Specifications	
LOA	14.30 m / 47.01 ft
Beam	7.70 m / 25.25 ft
Draft	1.10 m / 3.60 ft
Air Draft	21 m / 68.90 ft
Displacement	10.5 tonne
Sail Area Genoa	54 m ² / 581 sq ft
Sail Area Mainsail	78 m ² / 840 sq ft
Engines – larger optional	2 x 40 hp
Freshwater Capacity – larger optional	1 x 750 litre
Diesel Capacity – larger optional	1 x 480 litre
Architects and Designer	Berret - Racoupeau
Layout Options	Standard – 4 doubles / 4 bathrooms Owner's – 3 doubles / 3 bathrooms



Standard Version



Owner's Version

Flagship Class

Sanya 57

Fountaine Pajot, in association with the Berret Racoupeau design office, has produced a hallmark of definitive elegance and innovation.

The Sanya 57 is defined by its unique, contemporary design and has been strategically constructed for ocean cruising and unforgettably luxurious family holidays.

Affording all the pleasures of the sea, the Sanya 57 will take your breath away with the distinctive comfort, fixtures and services you've come to expect from Fountaine Pajot's prestigious Flagship Class.

This superb catamaran is the remarkable culmination of Fountaine Pajot's technological advances and innovative concepts, specifically designed for optimal safety and offshore performance.

The Lounge Deck is segregated from the helmstation and control lines, ensuring uninterrupted relaxation for guests while still allowing easy communication with the skipper.

Aesthetics are paramount and the boat's sleek lines are not compromised by practicality, with the solar panels integrated into the coachroof.

The ergonomic steering and maneuvering position affords panoramic visibility with a bimini to protect from inclement weather conditions, and is designed to be unobtrusive of the boat's living areas. The mainsail control lines are accessible from the coachroof.



The sheltered 25m² cockpit with sugar scoops is a welcoming and ambient area for relaxation. Its exclusive outdoor galley, equipped with sink, refrigerator, generous storage and adjustable table, helps create the perfect summer saloon. With custom-designed protection, it can double the closed sheltered area, all on the same level.

A remarkable 106m² of living area, all on one level, provides optimal space for enjoying cruises with treasured friends or unwinding in comfort on intimate getaways.

The dining and living room exude a refined yet relaxing ambience, courtesy of the discerning choice of textiles and furnishings, lighting, central island in galley, and the flexibility to customise the area's layout according to your specific needs. At anchor or at sea, the outstanding panorama is a unique signature of the Sanya 57.

For an 'à la carte' programme, or for family cruises, the six-cabin version offers beautiful guest cabins each featuring sea views and private bathroom. A guest bathroom, accessible via the main saloon, is a thoughtful design feature greatly appreciated when at sea. All cabins and passageways feature the latest in furnishings and fixtures with an impressive contemporary design.

Sanya 57 images are an artist's impression.





Flagship Class

Sanya 57

Specifications

LOA	17.26 m / 57.00 ft
Beam	8.88 m / 29.30 ft
Draft	1.40 m / 4.60 ft
Air Draft	23.10 m / 75.70 ft
Displacement	18.8 tonnes
Sail Area Genoa	65 m ² / 700 sq ft
Sail Area Mainsail	110 m ² / 1184 sq ft
Engines - larger optional	2 x 75 hp
Freshwater Capacity	1050 litre - larger optional
Diesel Capacity	1 x 1100 litre - larger optional
Architects and Designer	Berret - Racoupeau
Layout Options	Standard – 5 doubles + 1 crew cabin / 6 bathrooms Owner's – 4 doubles + 1 crew cabin / 5 bathroom

Sanya 57 images are an artist's impression.

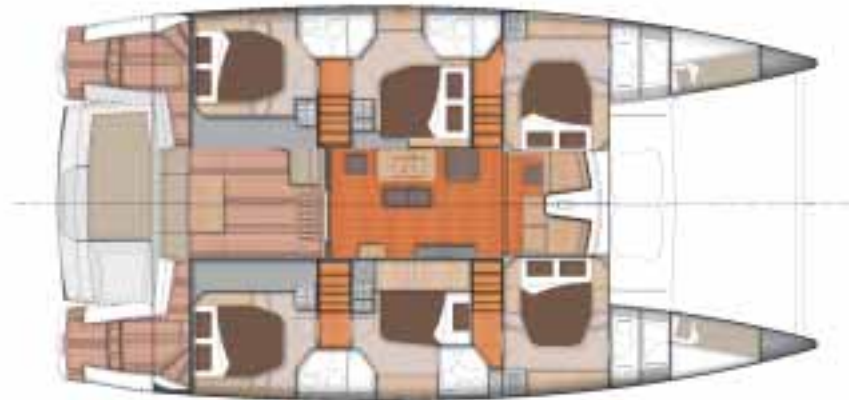

Standard Version



Owner's Version

Flagship Class

Galathea 65

The spectacular Galathea 65 is the largest cruising vessel ever built by Fountaine Pajot and is constructed with isophthalic resins in an all-infusion composite process, assuring the lightest yet strongest multihull construction method.

An outstanding creation from architects Berret Racoupeau and Coste Design, the Galathea 65 has been carefully designed with all of the performance, safety and comfort elements to satisfy the most discerning live aboard sailors and cruisers.

Superb offshore performance is generated from its balanced displacement, powerful sail plan and expanded waterline length. With remarkable square top sails, the catamaran delivers outstanding performance in challenging conditions while also optimising cruising speed in lighter winds.

The generous cockpit is fully protected while the deck affords easy manoeuvrability with all controls from the cockpit, large winches and a functional helm for fast, safe, comfortable and exhilarating sailing. The Galathea 65 also features an innovative two-part flybridge, with all the sails controls on the starboard side and a private saloon at port side.

The majestic interior is extraordinarily spacious with a panoramic saloon, dining room and gourmet galley and a choice of other areas for relaxation.



The Galathea offers numerous places to relax including a very large sunbaking deck which has been cleverly positioned to protect the tender from the natural elements.

The Owner's suite sets new standards in decadence and style with a study area, lounge and large bathroom with dual vanity. Each of the passenger cabins has their own bathroom, king size bed, large portholes and a style that rivals the world's top luxury hotels.

The Galathea 65 also includes an office/library, dressing rooms and laundry.

Standard equipment is more than comprehensive with special features including a 17.5 kw generator, ample cold storage facilities, 240v electrical network, electrical davits for the tender plus independent electric deck winches.

The catamaran is also the only true six-cabin vessel available to cater for prestige charter use, while other layouts are offered to cater for the unique needs of private and commercial clients.





Flagship Class

Galathea 65

Specifications

LOA	19.67 m / 65.53 ft
Beam	9.50 m / 31.16 ft
Draft	1.41 m / 4.62 ft
Air Draft	25.70 m / 84.30 ft
Displacement	23 tonne
Sail Area Genoa	78 m ² / 840 sq ft
Sail Area Mainsail	134 m ² / 1422 sq ft
Engines – larger optional	2 x 110 hp
Freshwater Capacity – larger optional	1 x 1000 litre
Diesel Capacity – larger optional	1 x 1400 litre
Architects and Designer	Berret - Racoupeau / Coste Design & Partners
Layout Option	Standard – 6 doubles / 4 singles Owner's – 4 doubles / 3 singles

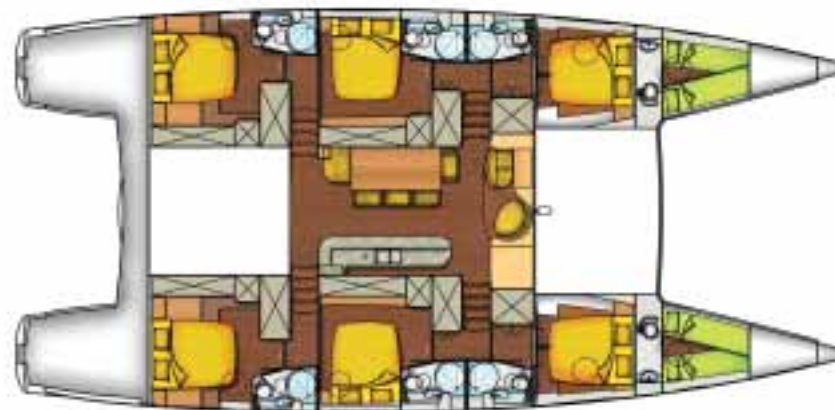

Standard Version

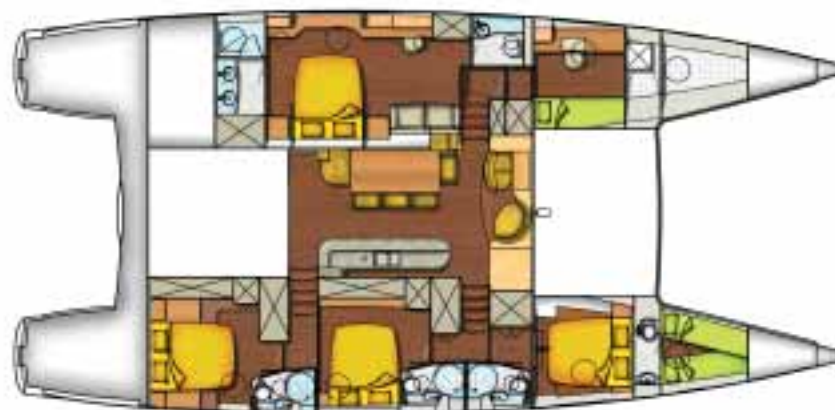

Owner's Version

Taiti 60 & 80

The Taiti 60 and Taiti 80 are sports catamarans specifically designed for commercial operators who conduct tailored and exclusive day charters for their guests. These catamarans are commonly used by large hotels, holiday clubs and tour operators.

They are renowned for providing excellent return on investment, as well as for their safety, easy manoeuvrability and elegant lines.

With proper streamlining similar to a racing boat, the Taiti catamarans have well-defined spaces, a two-hull design to prevent heeling, shallow draft for mooring and a low resistance hull shape for excellent performance under sail.

- High performance under sail
- Easy handling
- Stability
- Shallow draft for mooring

For more information on these custom built yachts, please contact us or visit our website at www.multihullsolutions.com.au



Specifications	Taiti 60	Taiti 80
LOA	18.20 m / 59.71 ft	23.75 m / 77.91 ft
Beam	9.10 m / 29.85 ft	10.70 m / 35.10 ft
Draft	1.25 m / 4.10 ft	1.60 m / 5.20 ft
Displacement	12.2 tonnes	21.5 tonnes
Sail Area Genoa	45 m ² / 484 sq ft	63 m ² / 678 sq ft
Sail Area Mainsail	95 m ² / 1022 sq ft	143 m ² / 1539 sq ft
Engines - larger optional	2 x 75 hp	2 x 110 hp
Freshwater Capacity - larger optional	2 x 350 litre	2 x 380 litre
Diesel Capacity - larger optional	2 x 300 litre	2 x 380 litre
Architects and Designer	Joubert - Nivelte	Joubert - Nivelte



Charter Investment

Charter industry overview

The bareboat and crewed charter boat holiday industry is experiencing exciting growth both in Australia and throughout the world. From its origins in the Mediterranean and Caribbean in the early '70s, the charter industry has flourished with charter fleets successfully operating from some of the world's most beautiful sailing grounds. Approximately 90 per cent of the boats operating in the charter fleets are not owned by the charter companies. They are owned by private individuals who operate their boats as a business to generate financial returns while also making use of their boat for regular holidays afloat.

The most common use is for week-long sailing holidays commonly known as "bareboat charters", which operate within Australia and around the world. "Bareboat" basically means chartering a boat without crew, which is the most popular option for clients with sailing experience who want to explore a cruising area with their own friends or family at their own pace.

Where do charter boats operate from?

Yachts can be chartered in areas such as Sydney Harbour, the Whitsundays, Fraser Island and Pittwater in Australia and other exotic cruising areas such as Tonga, Tahiti, New Caledonia, Phuket and Koh Samui in Thailand, Langkawi in Malaysia, Greece, Turkey and Croatia in the Mediterranean, and the ever popular islands of the Caribbean.



Are catamarans popular charter boats?

Throughout the charter fleets worldwide, it is a fact that catamarans are becoming the most popular charter boats. Apart from their fantastic sailing performance, hiring a catamaran offers the following advantages over chartering a monohull:

- Firstly, you can't go past the abundance of extra space both above and below decks. Catamarans can comfortably accommodate up to 12 people depending on their size.
- They provide a stable platform while sailing and when anchored. You experience little to no heeling over when sailing, and when at anchor there is no rolling around in anchorages guaranteeing a peaceful night's sleep.
- Catamarans have a much shallower draft than monohulls which allows anchoring close to shore in the most protected anchorages accessible.
- Ease of handling - if you can sail a monohull you can sail a catamaran. Most charter catamarans are set up with furling headsails and slab reefing mainsails (with lazy jacks) with all lines running back to the helm station and cockpit. They also have two engines making manoeuvring a breeze.



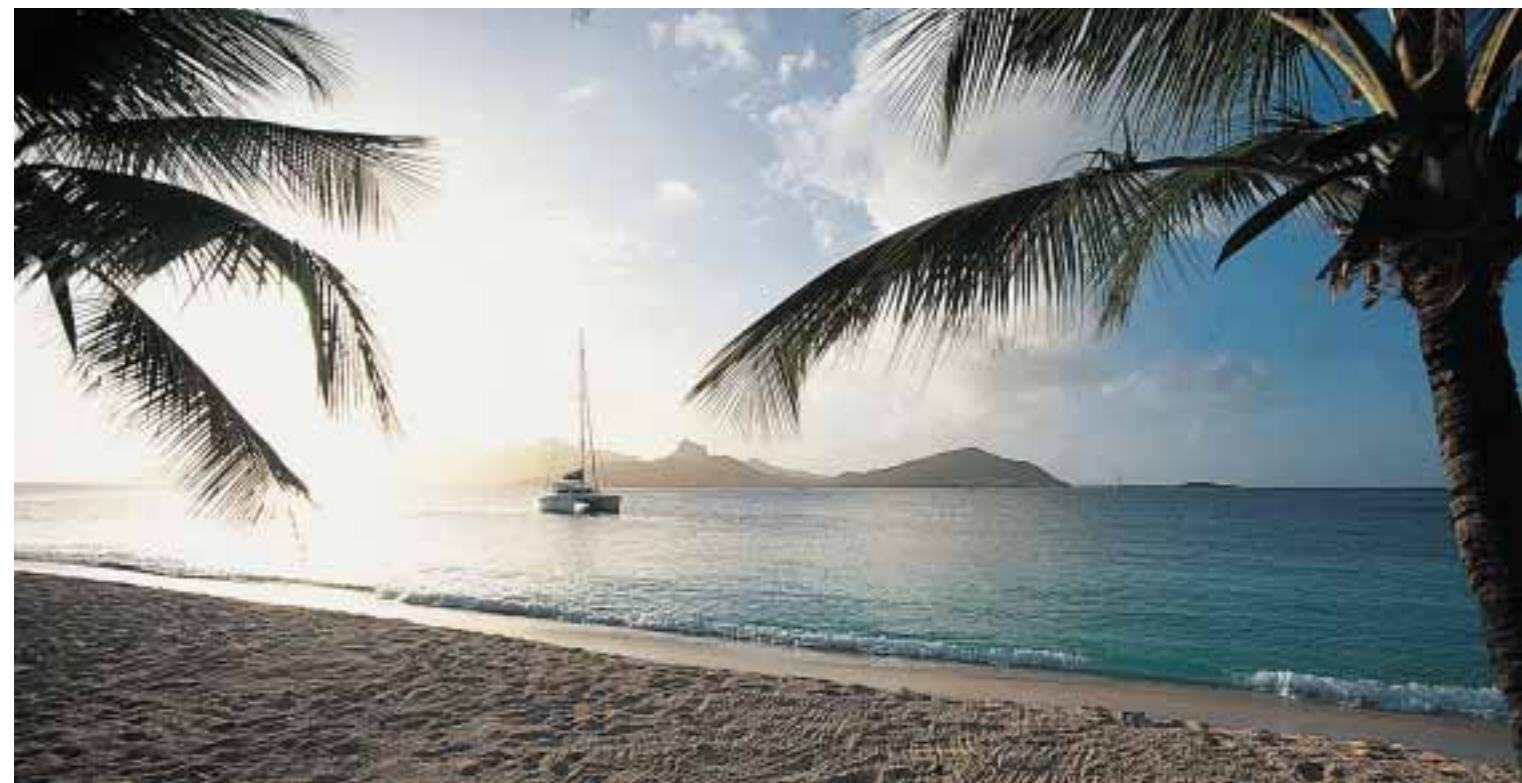

Charter Investment

What type of multihulls fit best into charter?

Multihull Solutions understands most of the world's charter regions, its charter operators and how they run their businesses. Some operators' management style may not suit you, while others are an ideal fit. Often overlooked is that the boat you are considering to purchase may not suit that particular operator's customer base.

There are many issues to consider: boat size, layout, equipment, term of charter management, location, market conditions, operator's target market, and both the operator's and owner's expectations.

Above all, you need to determine whether your boat be considered a "full charter boat business" or a "hobby based business" by the Australian Taxation Office. This is the most important first step. We can make sure your boat is in the right location and with the most suitable operator for your particular boat, so you can enjoy the business!

What we offer

The Multihull Solutions team has worked with the charter boat industry for over 15 years and understands the position of both the boat owner and the operator. Like any relationship, the most important initial consideration is to find the right balance.



Multihull Solutions can assist you in sourcing and buying the right new or pre-owned multihulls to fit into a charter fleet. We have close relationships with the most reputable charter companies to ensure your asset is well maintained and looked after at all times.

We also offer a range of quality pre-owned charter yachts for sale. We have a wide range of catamarans for sale for either continued use in a charter boat holiday company or for placement into private use.

Multihull Solutions works with well respected finance company Finlease to assist with understanding financing of your yacht, and Oceanic Insurance Brokers to assist with boat insurance.

Summary

Buying a multihull for commercial operation is not a simple process, so we strongly recommend you take your time and complete all due diligence. We also suggest that you don't make a decision to buy based solely on price and your personal preferences - the boat is the business and must be a compromise to ensure it meets all requirements for business success.

For more information on charter investment, please don't hesitate to contact us or visit our website

www.multihullsolutions.com.au

Why Fountaine Pajot?

Fountaine Pajot
C A T A M A R A N S

- Safety – Fountaine Pajot catamarans are rated as “unsinkable”.
- Performance / cruiser – each has an excellent balance of performance and comfort.
- Ease of use – all sailing catamarans are designed for easy handling by just one or two persons.
- Design and technology – Fountaine Pajot’s team of internationally renowned architects, designers and builders is continually improving the range to combine the very latest in design and technology.
- Value for money – Fountaine Pajot catamarans offer proven, stylish designs and outstanding performance at an affordable price.
- Global brand – Fountaine Pajot catamarans are recognised internationally, ensuring you enjoy worldwide service and support, plus easy availability of spare parts when required.

Fountaine Pajot’s range of premier cruising catamarans offers an unparalleled combination of performance and comfort. With stylish designs featuring sleek lines and stunning contemporary interiors, each model is carefully appointed to make every voyage a pleasure. Fountaine Pajot’s catamarans are available in a range of sizes and interior layouts to cater for every client’s individual requirements, making them perfect for day trips, weekend sailing, coastal and offshore cruising.

Shipping

Fountaine Pajot catamarans are sailed/powered from the factory in France across the English Channel to Southampton where they are disassembled and loaded aboard selected suitable ships. This “sea trial” ensures all systems are in proper working order before the vessel is delivered to Multihull Solutions.

On arrival in Australia or New Zealand, Multihull Solutions oversees the transfer of the vessel from the ship to the dock and its launch into the water, where our team then handles the full commissioning process (eg. standing of mast, fitting of sails, biminis, electrical and gas compliance etc). A Multihull Solutions sales representative then manages all inspections and sea trials with the client before handing the vessel over.

If clients prefer to collect their vessel personally from the factory in France and make their own way back to Australia/ New Zealand, ex-factory handovers can also be arranged.

For more information, please contact us or visit our website at

www.multihullsolutions.com.au



www.fountainepajot.com.au



Multihull Solutions Australia

33-45 Parkyn Parade, Mooloolaba, QLD, Australia 4557

Tollfree 1300 855 338

International +61 (0) 7 5452 5164

Fax +61 (0) 7 5444 3792

Email info@multihullsolutions.com.au

Multihull Solutions New Zealand

9 Westhaven Drive, Westhaven, Auckland, New Zealand

Tollfree 0508 MULTIS (0508 68 58 47)

International +64 (0) 9 903 1000

Email info@multihullsolutions.co.nz

www.multihullsolutions.com.au

Fountainepajot
C A T A M A R A N S

multihull
SOLUTIONS